

DETAIL 1

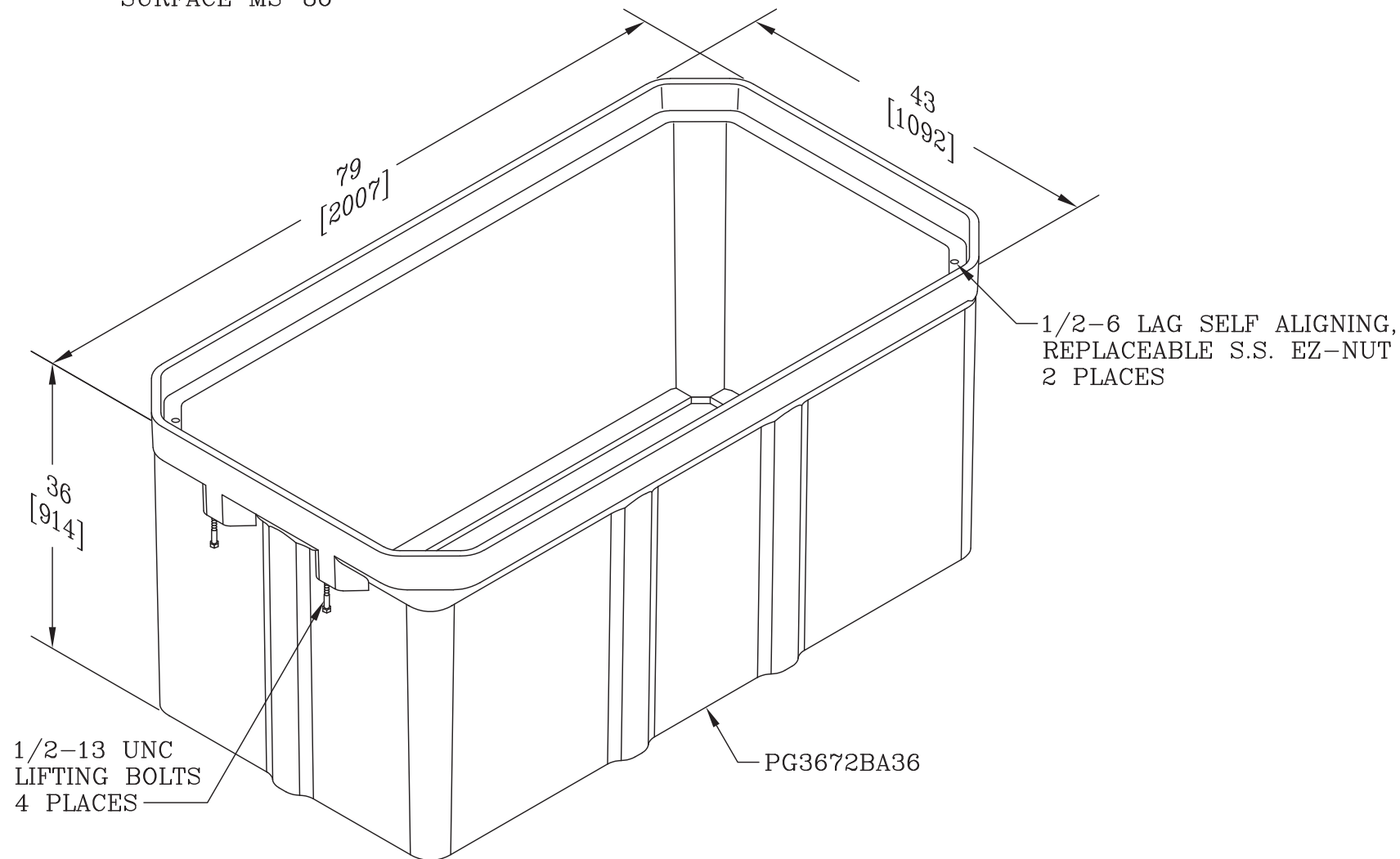

NOTES:

1. CUSTOMER IS LOGO TO BE SPECIFIED: \_\_\_\_\_.
2. THIS ASSEMBLY IS RATED FOR PEDESTRIAN TRAFFIC ONLY.
3. THIS ASSEMBLY FITS A CALIX ODC1000 CABINET
4. ALL ENCLOSURES, BOXES AND COVERS ARE REQUIRED TO CONFORM TO ALL TEST PROVISIONS OF ANSI/SCTE 77 2007 "SPECIFICATION FOR UNDERGROUND ENCLOSURE INTEGRITY" AS MANUFACTURED BY QUAZITE OR EQUIVALENT WITH RURAL TEL'S ENGINEER'S SIGNED APPROVAL. THE BOXES MUST BE RATED FOR TIER 22 APPLICATIONS AN IN NO ASSEMBLY CAN THE COVER DESIGN LOAD EXCEED THE DESIGN LOAD OF THE BOX. ALL COMPONENTS IN AN ASSEMBLY (BOX & COVER) ARE MANUFACTURED USING MATCHED SURFACE TOOLING. ALL COVERS ARE REQUIRED TO HAVE A MINIMUM COEFFICIENT OF FRICTION OF 0.50 IN ACCORDANCE WITH ASTM C1028.



V1000-367236

PC VAULT AND LID, ODC 1000 – FAC 3200, 36 X 72 X 36