

FieldSmart Small Count Delivery (SCD)

Outdoor/Indoor Wall Box - Enclosure for Clearview xPAK

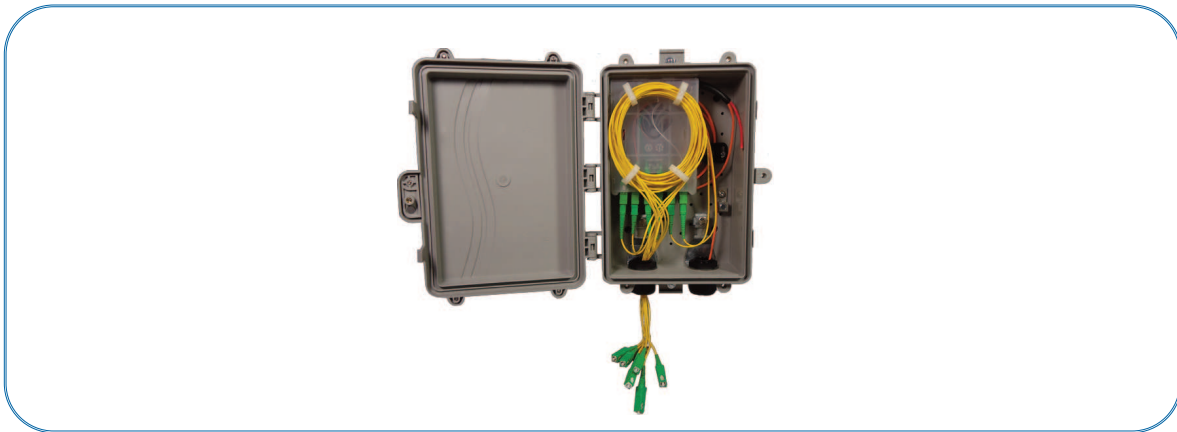

Application

- Fiber Demarcation
- Entrance Facilities
- Security Systems (CCTV)
- MDU (Multi-Dwelling Units) applications
- FTTP internal drop box
- Business Class Services
- RFoG scenarios
- Traffic monitoring/ DOT
- Telecommunication Room
- Power/Wind farm applications
- Cell Backhaul

Description

Ideal for any small-count "landed" fiber scenarios where 2,4, or 6 fibers are required in a discrete footprint without sacrificing fiber management. Optimized for use with the Clearview xPAK.

Features & Benefits

Integrity

- Utilizing the Clearview xPAK, it supports industry standard SC and LC singlemode connectors
- Dual snap locks to ensure lid seals to base
- Mounting hole pattern for multiple applications

Protection

- Radius protected storage for up to 15 feet of buffer tube
- NEMA 4 rated
- Security screw with ability to secure with padlock
- Gasket seal
- Ground lug included

Access

- Small design facilitates ease of use in crowded environments
- Easy to install with both internal and external mounting holes
- (2) bottom entry / exit points

Investment

- Patch and splice or patch only
- Surface or pole mount capable
- Flame retardant PVC for durability

SCD Outdoor/Indoor Wall Box

FieldSmart Small Count Delivery (SCD)

Outdoor/Indoor Wall Box - Enclosure for Clearview xPAK

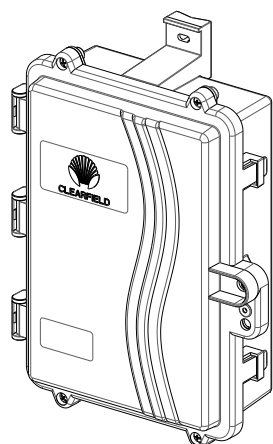

Front - Closed

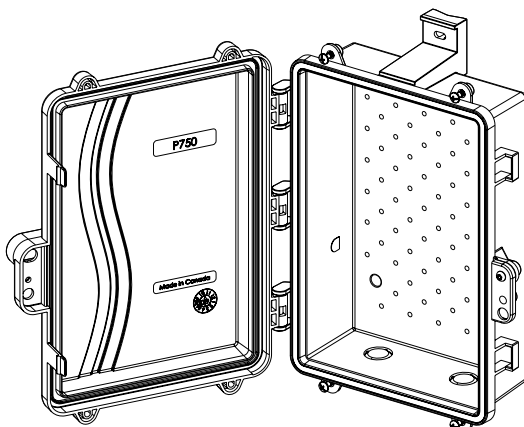

Front - Open

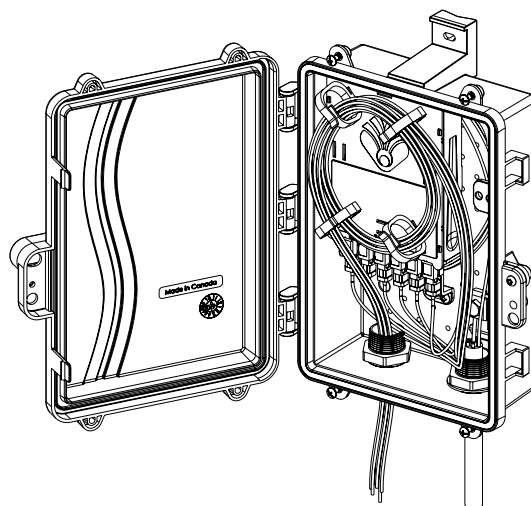

Front - Loaded with Clearview xPAK
(xPAK not included)

Dimensions

	Width	Length	Depth
External	9"	12"	4"
Internal	6"	9"	2.25"

Pre-configured Part Numbers

Part Number	Description
FDP-xWB1	Wall box with 1 fitting
FDP-xAK1	Optional accessory Kit (Includes 1 fitting and 2 strength member clamps)