

DWDM uses up to 160 different colors (also known as lambda or channels) to provide high-capacity bandwidth across an optical fiber network. Each lambda carries an individual optical signal providing the same bandwidth per channel (approximately 2.4G bit/sec with most of today's fiber) as a single light stream.

It is easy to understand WDM. Consider the fact that you can see many different colors of light - red, green, yellow, blue, etc. all at once. The colors are transmitted through the air together and may mix, but they can be easily separated using a simple device like a prism, just like we separate the "white" light from the sun into a spectrum of colors with the prism.

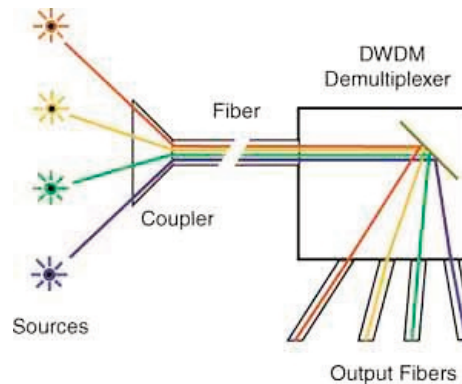

This technique was first demonstrated with optical fiber in the early 80s when telco fiber optic links still used multimode fiber. Light at 850 nm and 1300 nm was injected into the fiber at one end using a simple fused coupler. At the far end of the fiber, another coupler split the light into two fibers, one sent to a silicon detector more sensitive to 850 nm and one to a germanium or InGaAs detector more sensitive to 1300 nm. Filters removed the unwanted wavelengths, so each detector then was able to receive only the signal intended for it.

The input end of a WDM system is really quite simple. It is a simple coupler that combines all the inputs into one output fiber. These have been available for many years, offering 2, 4, 8, 16, 32 or even 64 inputs. It is the de-multiplexer that is the difficult component to make.

A WDM system has some features that make them very useable. Each wavelength can be from a normal link, for example a OC-48 link, so you do not obsolete most of your current equipment. You merely need laser transmitters chosen for wavelengths that match the

WDM de-multiplexer to make sure each channel is properly decoded at the receiving end. If you use an OC-48 SONET input, you can have $4 \times 2.5 \text{ GB/s} = 10 \text{ GB/s}$ up to $32 \times 2.5 \text{ GB/s} = 80 \text{ GB/s}$. While 32 channels are the maximum today, future enhancements are expected to offer 80-128 channels! And you are not limited to SONET, you can use Gigabit Ethernet for example, or you can mix and match SONET and Gigabit Ethernet or any other digital signals! You can even mix in analog/RF channels like CATV, as is done with EPON/BPON/GPON FTTH systems.

Originally, the term "Coarse Wavelength Division Multiplexing" was fairly generic, and meant a number of different things. In general, these things shared the fact that the choice of channel spacings and frequency stability was such that erbium doped fiber amplifiers (EDFAs) could not be utilized. Prior to the relatively recent ITU standardization of the term, one common meaning for Coarse WDM meant two (or possibly more) signals multiplexed onto a single fiber, where one signal was in the 1550-nm band, and the other in the 1310-nm band.

Recently the ITU has standardized a 20 nanometer channel spacing grid for use with CWDM, using the wavelengths between 1310 nm and 1610 nm. Many CWDM wavelengths below 1470 nm are considered "unusable" on older G.652 specification fibers, due to the increased attenuation in the 1310-1470 nm bands. Newer fibers which conform to the G.652.C and G.652.D standards, such as Corning SMF-28e and Samsung Wide pass nearly eliminate the "water peak" attenuation peak and allow for full operation of all twenty ITU CWDM channels in metropolitan networks.

A relatively recent development relating Coarse WDM is the creation of GBIC and Small Form Factor Pluggable (SFP) transceivers utilizing standardized CWDM wavelengths. GBIC and SFP optics allow for something very close to a seamless upgrade in even legacy systems that support SFP interfaces. Thus, a legacy switch system can be easily "converted" to allow wavelength multiplexed transport over a fiber simply by judicious choice of transceiver wavelengths, combined with an inexpensive passive optical multiplexing device.

200 Ghz DWDM

Parameter	Unit	Value				
		Add/Drop	4CH	8CH	16CH	20CH
Wavelength Range	nm	1520-1560				
Central Wavelength		ITU-T GRID				
Bandwidth	nm	c +/-0.25				
Insertion Loss	dB	<0.8	<2.0	<3.0	<3.5	<4.0
Insertion Loss (Reflection)	dB	<0.3	na	na	na	na
Isolation	dB	>28				
Isolation (Reflection)	dB	>12	na	na	na	na
Uniformity of I.L.	dB	na	<1	<1	<1	<1
PDL	dB	<0.2				
Return Loss	dB	>45				
Operation Temperature	°C	-5 -65				
Storage Temperature	°C	-40 -85				
Maximum Input Power	mW	500				
Mechanical Dimension	mm	3.6 (D) x 40 (L)	100 x 80 x 8	100 x 80 x 8	100 x 80 x 16	100 x 80 x 16

100 Ghz DWDM

Parameter	Unit	Value				
		Add/Drop	4CH	8CH	16CH	40CH
Wavelength Range	nm	1520-1560				
Central Wavelength		ITU-T GRID				
Bandwidth	nm	c +/-0.11				
Insertion Loss	dB	<0.8	<2.5	<3.5	<4.0	<5.5
Insertion Loss (Reflection)	dB	<0.3	na	na	na	na
Isolation	dB	>28				
Isolation (Reflection)	dB	>12	na	na	na	na
Uniformity of I.L.	dB	na	<1	<1	<1	<1
PDL	dB	<0.2				
Return Loss	dB	>45				
Operation Temperature	°C	-5 -65				
Storage Temperature	°C	-40 -85				
Maximum Input Power	mW	500				
Mechanical Dimension	mm	3.6 (D) x 40 (L)	100 x 80 x 8	100 x 80 x 8	100 x 80 x 16	100 x 80 x 16

CWDM

Parameter	Unit	Value		
		Add/Drop	4 CH	8 CH
Wavelength Range	nm	1471 - 1611		
Bandwidth	nm	c +/-6.5		
Insertion Loss	dB	<0.8	<2.0	<3.0
Insertion Loss (Reflection)	dB	<0.3	na	na
Isolation	dB	>30		
Isolation (Reflection)	dB	>12	na	na
Uniformity of I.L.	dB	na	<1	<1
PDL	dB	<0.2		
Return Loss	dB	>45		
Operation Temperature	°C	-5 -85		
Maximum Input Power	mW	500		
Mechanical Dimension	mm	3.6 (D) x 40 (L)	100 x 80 x 8	100 x 80 x 8

FSAN WDM

WDM (EWDM) Specifications			
Parameter	Ports	Unit	Specifications
Pass Channel Wavelength	P1 --> P3	nm	1260-1360
			1480-1500
Reflect Channel Wavelength	P1 --> P2	dB	1540-1565
Insertion Loss	P1 <--> P3	dB	<0.8
		dB	<0.5
Isolation		dB	>25
		dB / °C	>18
PDL		dB	<0.2
Ripple		dB	<0.3
PDL		dB	<0.2
Return Loss		dB	>45
Operating Temperature Range		°C	-5° - 65°
Storage Temperature Range		°C	-40° - 85°
Maximum Input Power		mW	500
Mechanical Dimension		mm	3.6 (D) x 40 (L)